

Cabmate[®]
Cab Suspension

LINK[®]

Link Mfg. Ltd.
223 15th St. N.E.
Sioux Center, IA USA
51250-2120
www.linkmfg.com

**QUESTIONS?
CALL CUSTOMER
SERVICE
1-800-222-6283**

INSTALLATION INSTRUCTIONS PARTS LIST

PBC379-A (2840-C000)

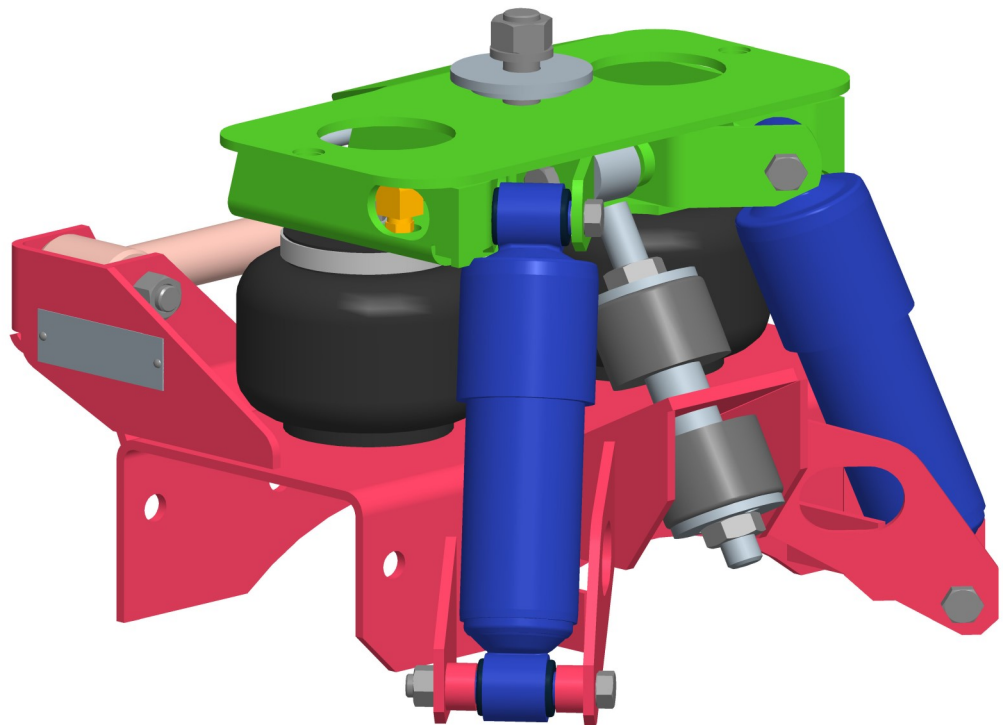

The **CABMATE MODEL PBC379-A** fits most Peterbilt 379, 359 and 330 Conventionals. It replaces the original cab support, Peterbilt Part No. 20-15951, 20-13321, or 20-00621. (It may also fit older **359** Conventionals with aluminum crossmember, with crossmember substitution.) **Dual exhaust requires ordering an additional exhaust bracket, Link Part No. 2899-A000. This unit will not fit trucks equipped with Able Body Sleepers.**

UNIT WEIGHT WITH
1 EXHAUST BRACKET: 37.3 LB.

NET WEIGHT ADDED: 22.9 LB.

CABMATE MODEL PBC379-A

Review the Parts List on page 3 to become familiar with the different components of the CABMATE.

IMPORTANT: Due to many chassis variables caused by installation of special equipment or options, the fit of the PBC379-A CABMATE may be affected and should be evaluated before beginning installation.

IMPORTANT: Installation of the CABMATE system will allow the cab to move freely. Before starting installation, check clearances between the cab and any objects the cab may contact when it moves (1 1/2 inches of clearance should be sufficient). The clearance of components that are affected by cab movement, such as exhaust and radiator systems, must also be evaluated.

Conversion for trucks manufactured before October 1992: Installation on trucks manufactured before October 1992, will require drilling additional holes and the use of additional mounting hardware. Refer to the insert for additional installation instructions prior to the installation of the CABMATE.

Conversion for 330 and 359 truck models: Installation on 330 and 359 truck models will require valve linkage substitution and adjustment of the travel limiter bumpers. Refer to the insert for additional installation instructions prior to installation of the CABMATE.

A. Remove the stock mount bolts from the bottom of the original rear cab mount. Securely prop up the cab and remove all stock mount parts.

B. Slide the CABMATE between the cab and the crossmember from underneath the cab. Loosely fasten the Unit Bottom to the crossmember using the eight 1/2" mount bolts (Item Nos. 11 and 22 from parts list).

HINT: It may be easier to first drop the cross member, mount the CABMATE to the cross member, and then reinstall the cross member.

C. Lower the cab until it touches the top of the CABMATE. With the Unit Top and the Unit Bottom aligned, fasten the Unit Top to the cab using the 5/8" mount bolt (Item Nos. 12, 19 and 26 from parts list). **SECURELY TIGHTEN ALL FASTENERS.**

D. See page 2 for plumbing instructions and height adjustments. With unit set to the correct design height, loosen the two 5/8 Jam Nuts on the Travel Limiter, and adjust the bumpers according to the dimensions in Fig. 2. Securely tighten the 5/8 Jam Nuts after adjusting.

E. **IMPORTANT:** After plumbing and height control adjustments are completed, temporarily adjust the CABMATE to its maximum upward position. There must be a 1/4" to 3/8" gap between the cab and the hood. Adjust the hood hinge forward as necessary (Fig. 3).

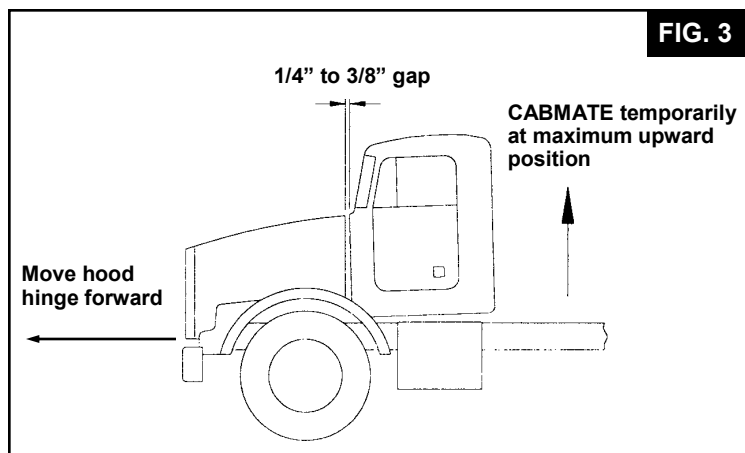
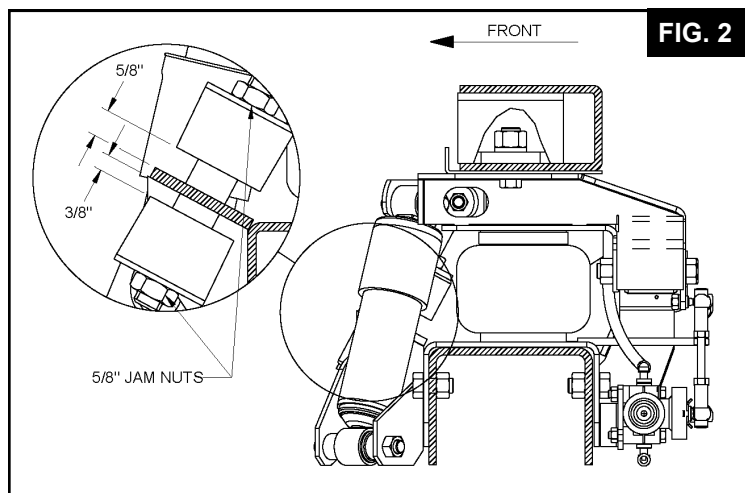
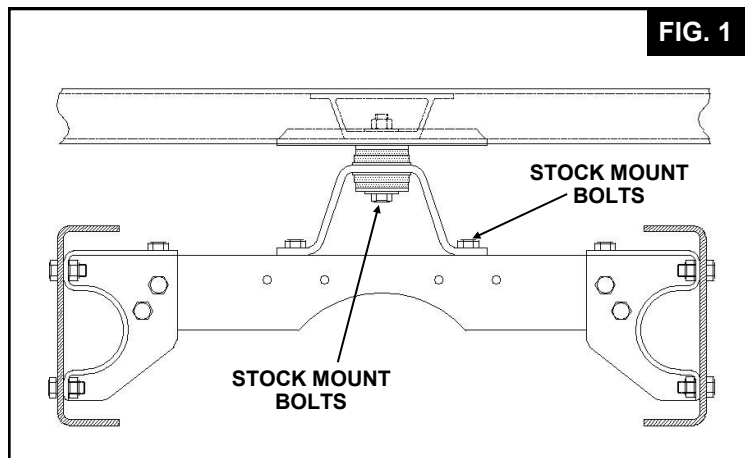

CONVERSION FOR TRUCKS MANUFACTURED BEFORE OCTOBER 1992

NOTE: Look at the bottom of the cab sill, to check the diameter of the mount hole. If the center mount hole is 1 3/4 dia. the following steps must be followed.

- A. Make a mark 5 1/8 inches from the center of the 1 3/4 dia. Mount hole, and parallel to the cab sill, on each side of the 1 3/4 dia. mount hole. Drill a 15/32 dia. hole on the center of the two marks as shown in Fig. 4.
- B. Place the After Market Mount Bushing in the 1 3/4 dia. Mount hole of the cab sill as shown in Fig. 5.

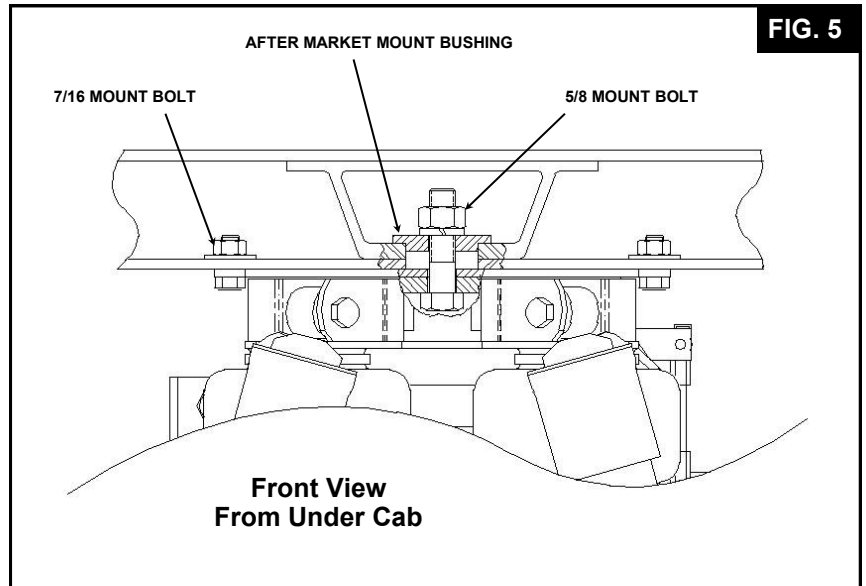
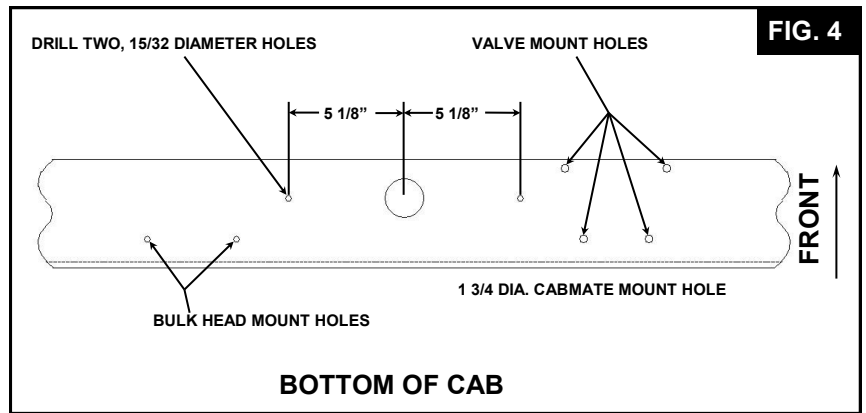

CONVERSION FOR 330 AND 359 TRUCK MODELS

- A. Remove the original valve linkage from the unit, by snapping the plastic socket ends off the pivot balls (Fig. 6).
- B. Replace the valve linkage with the one in the plastic baggy. This valve linkage is 1/4 in. shorter than the original.
- C. The design height of the unit will be changed to 3 1/2 in. This is 1/4 in. shorter than the standard design height.

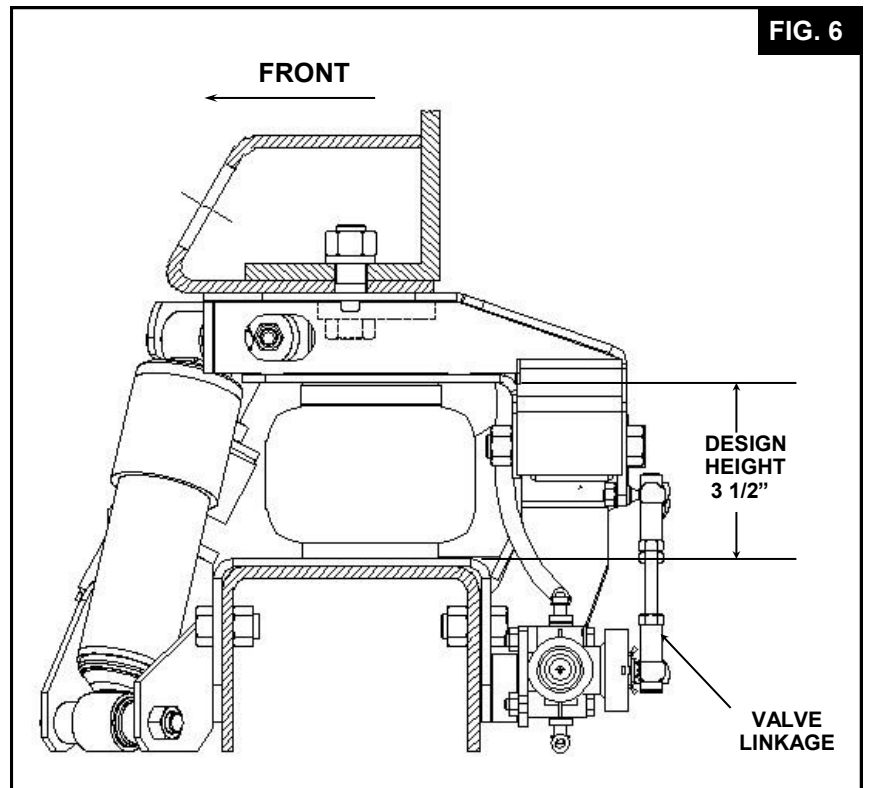

SPECIAL NOTE FOR UNIBILT RETROFIT

Retrofitting CABMATE Model
PBC379-A, after removing the
UNIBILT sleeper, requires a
REAR CAB SILL INSERT.
Peterbilt Part No. 20-16591.

PLUMBING INSTRUCTIONS

WARNING: FOR SAFTY PURPOSES THE CABMATE MUST BE SUPPLIED FROM A PRESSURE PROTECTED CIRCUIT. IN THE EVENT OF AN AIR LEAK IN THE CAB SUSPENSION, FAILURE TO PROVIDE A PRESSURE PROTECTED CIRCUIT MAY CAUSE LOSS OF AIR PRESSURE TO VITAL SYSTEMS ON THE VEHICLE.

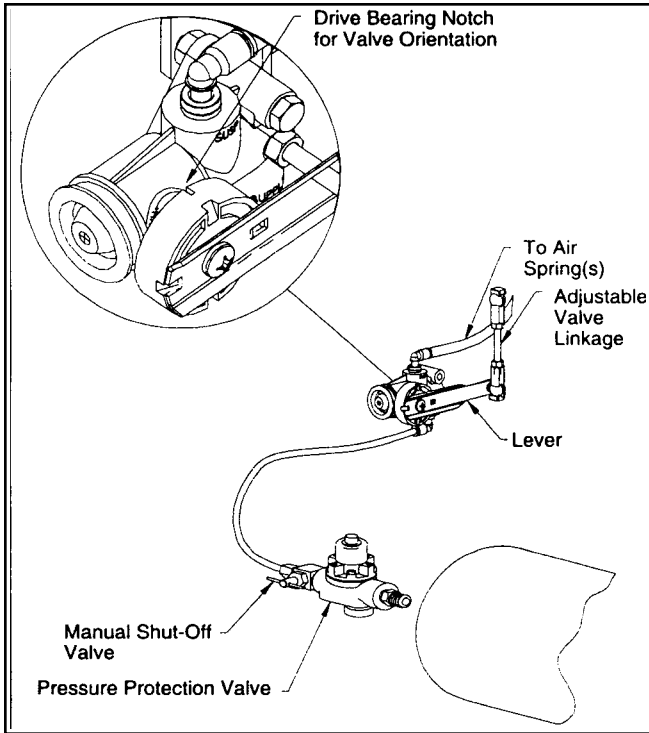

WARNING: LOSS OR APPLICATION OF AIR PRESSURE TO CABMATE WILL CAUSE SUDDEN MOVEMENT OF THE CAB. PRIOR TO INSTALLING OR PERFORMING MAINTENANCE, BLOCK UP THE CABMATE TO PREVENT THE POSSIBILITY OF INJURY.

WARNING: CONNECT THE CABMATE DIRECTLY TO THE MAIN AIR TANK. YOU WILL NEED AN AIR PRESSURE PROTECTION VALVE IN THE LINE. (INCLUDED IN THE PRESSUREPROTECTION KIT. LINK MFG. PART NO. 1350-0000). DO NOT USE AN AIR PRESSURE REGULATOR!

A. With the tank at 0 p.s.i., remove the existing plug or fitting from the desired port.

B. Apply joint compound to the fittings and install the pressure protection kit. **DO NOT USE TEFLON TAPE.** Be sure that the arrows on the valve are pointing in the direction of air flow and the vent hole is pointed down. **NOTE:** Additional fittings/reducers may be required to attach the hex nipple to the main air tank.

C. Run the 1/4" airline from the shut-off valve to the CABMATE. Be sure that the airline has enough clearance so that there are no pinch points that may restrict or cut the airline. Secure the airline using the cable ties supplied by Link Mfg.

D. Tighten all plumbing fittings. Then, with the system at operating pressure (90 to 110 p.s.i.), open the Manual Shut-off Valve to supply air to the CABMATE. Check the system for air leaks.

E. Check for proper operation of the height control valve. Disconnect the valve linkage from the lever. Push the lever down 45°, air should flow into the air spring(s). Return the lever to the neutral position. Push the lever up 45°, air should exhaust from the air spring(s). Return the lever to the neutral

position; no air should flow. Reconnect the valve linkage to the lever.

HEIGHT ADJUSTMENTS

Measure the design height of the air spring(s). The height should be 3.75 inches ± 1/16. To change the height, disconnect one end of the valve linkage and adjust accordingly. Tighten the lock nuts on the valve linkage.

MAINTENANCE

CABMATES need no lubrication and little maintenance. The following components should be checked at the time the truck is being serviced. However, immediate corrective action should be taken if a serious malfunction occurs.

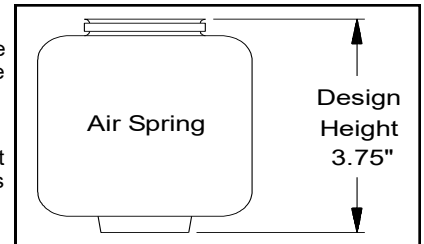

COMPONENT	POSSIBLE PROBLEM	CORRECTIVE ACTION	TORQUE
Airlines	Air leaks	Replace airline	Compression Nut Hand Tight + 1 Turn
Fittings	Air leaks	Remove fitting and apply fresh joint compound. Reinstall fitting, but Do Not Overtighten. Do not use teflon tape.	Threaded into: Metal Plastic 15 Hand Tight Ft. Lbs. + 1 Turn
Air Springs	A. Improper height B. Air leakage	A. Adjust valve linkage to maintain proper air spring height. B. Replace air spring.	Size Metal Plastic 3/8 25 Ft. Lbs 04 Ft. Lbs 1/2 28 Ft. Lbs 10 Ft. Lbs 3/4 30 Ft. Lbs 10 Ft. Lbs
Height Control Valve	Air spring(s) will not inflate when wheight is added to the cab; OR Air spring(s) will not deflate when wheight is removed from the cab.	A. Inspect valve to insure drive bearing notch is located on "SUSP" port side of valve. If not, loosen lever screw (but do not remove completely) and pull lever loose from drive bearing, rotate drive bearing until the bearing notch is in the correct position and resecure lever by tightening lever screw. B. Replace Valve	1/4 Mount Fasteners 10 Ft. Lbs. Bearing Screw 40-50 InLbs.
Shock Absorber	Insufficient dampening effect	Replace shocks	45 Ft. Lbs.
Lateral Control Rod	A. Loose nuts on lateral control rod bolts B. Worn bushings.	A. Tighten securely to clamp the inner sleeve. B. Replace lateral control rod.	40 Ft. Lbs.

IMPORTANT: Periodically check the tightness of all fasteners.

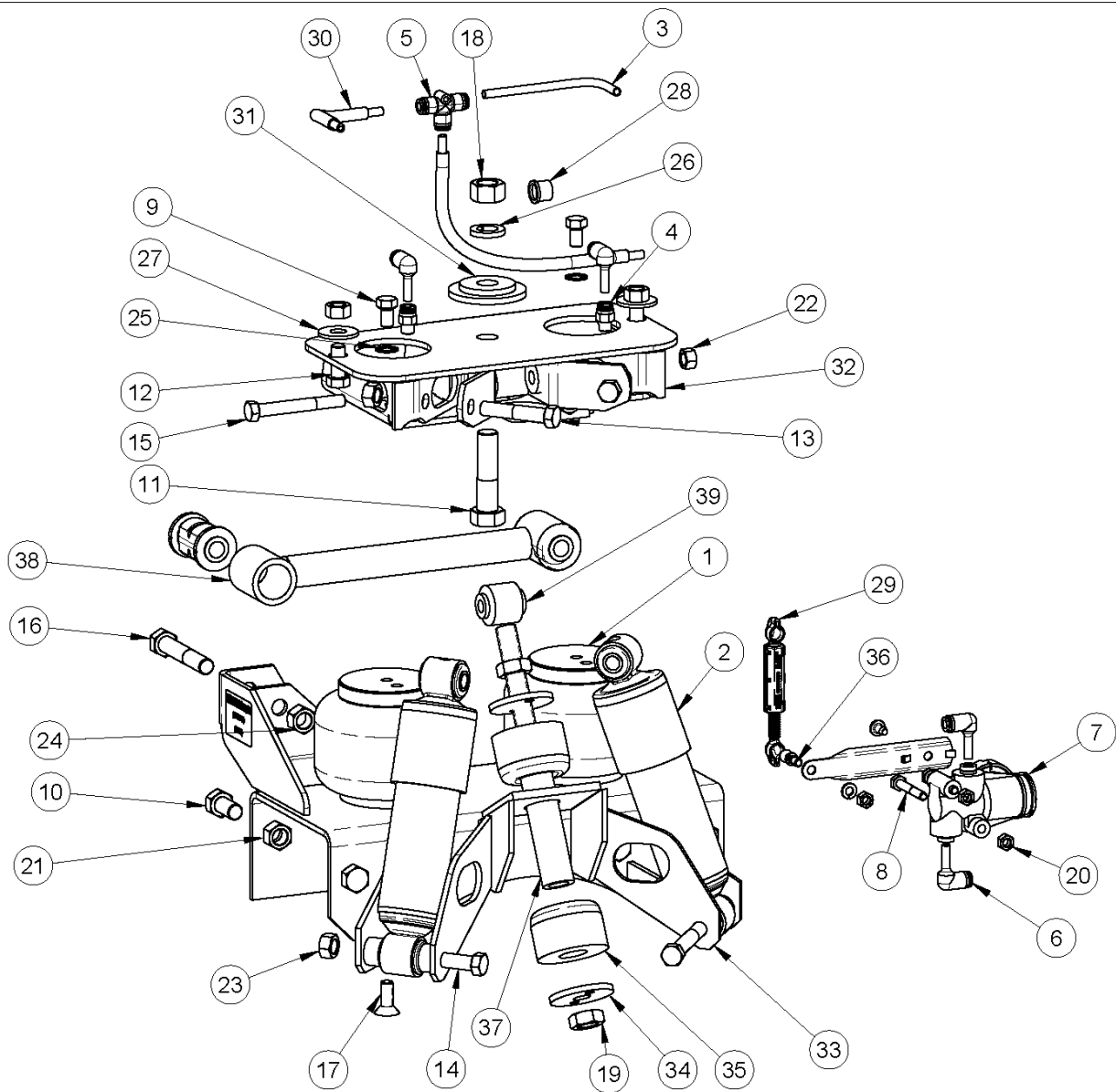

CABMATE[®] MODEL PBC379-A PARTS LIST

ITEM	PART NO.	DESCRIPTION	QTY	ITEM	PART NO.	DESCRIPTION	QTY
1	11020022	SPRING-AIR	2	22	14771201	3/8 UNF HEX TOP LOCK NUT (GR C)	1
2	12010054	SHOCK ABSORBER	2	23	14771400	7/16 UNF HEX CTR LOCK NUT (GR B)	6
3	13020090	AIRLINE-NYLON, .250 O.D., BULK	1.9 ft	24	14771601	1/2 UNF HEX TOP LOCK NUT (GR C)	2
4	13025201	CONNECTOR, 1/4 TB 1/8 M-NPT	2	25	14851205	3/8 INT TOOTH LOCK WASHER, ZINC	2
5	13025205	UNION TEE, 1/4 TB	1	26	14852000	5/8 LOCK WASHER	1
6	13025499	ELBOW-PLUG-IN, 1/4"	4	27	14871400	7/16 TYPE A PLAIN WASHER	2
7	13500101	SERVICE KIT-HEIGHT CONTROL VALVE	1	28	15000303	SNAP BUSHING (.250 MAT'L)	1
8	14010814	1/4 X 1 3/4 UNC HEX CAP SCR (GR 5)	2	29	15000370	LINKAGE-VALVE, SHORT	1
9	14011205	3/8 X 5/8 UNC HEX CAP SCR (GR 5)	2	30	15000435	LOOM-CORRUGATED, .250, BULK	1.3 ft
10	14011608	1/2 X 1 UNC HEX CAP SCR (GR 5)	8	31	28350001	AFTERMARKET MOUNT BUSHING	1
11	14012020	5/8 X 2 1/2 UNC HEX CAP SCR (GR 5)	1	32	28403000	UNIT TOP	1
12	14031408	7/16 X 1 UNF HEX CAP SCR (GR 5)	2	33	28405000	UNIT BOTTOM	1
13	14031418	7/16 X 2 1/4 UNF HEX CAP SCR (GR 5)	2	34	29900049	TRAVEL LIMITER WASHER	2
14	14031426	7/16 X 3 1/4 UNF HEX CAP SCR (GR 5)	2	35	29900050	TRAVEL LIMITER BUMPER	2
15	14041224	3/8 X 3 UNF HEX CAP SCR (GR 8)	1	36	29910026	SERVICE KIT-PIVOT BALL	2
16	14041624	1/2 X 3 UNF HEX CAP SCR (GR 8)	2	37	29923001	TRAVEL LIMITER WEAR SLEEVE (4.25)	1
17	14171208	3/8 X 1 UNC SOC FLAT CSK HD CAP SCREW	2	38	29932012	LATERAL CONTROL ROD	1
18	14702000	5/8 UNC HEX NUT (GR B)	1	39	29923202	TRAVEL LIMITER ROD ASSEMBLY (7.75)	1
19	14742000	5/8 UNC HEX JAM NUT	2	-	28990000	PB5XS	1
20	14760800	1/4 UNC HEX CTR LOCK NUT (GR B)	2	-	38401001	KIT-DOCUMENT, PBC379-A (AFTM)	1
21	14761600	1/2 UNC HEX CTR LOCK NUT (GR B)	8				



LINK MANUFACTURING, LTD.
223 15TH ST. NE, SIOUX CENTER, IA 51250
1-800-222-6283 www.linkmfg.com